

# GE Honda Aero Engines



## HF120 Turbofan

### Design

Integrating the technology and quality of GE and Honda, the HF120 turbofan from GE Honda Aero Engines has been developed with the future of business aviation in mind. A robust, simplified design is expected to deliver greater payload, longer range and outstanding durability.

### Performance

High-flow, wide-chord fan blades, high temperature materials and advanced features are expected to provide real performance advantages, like a high thrust-to-weight ratio and reduced fuel burn. With a time between overhaul at 5,000 hours and no need to open the engine for interim hot-section inspections, the HF120 is designed to stay on-wing over 40% longer than other business jet engines.

### Environment

By reducing weight and incorporating innovative 3D aerodynamic designs, the engine components are designed to interact with greater efficiency while optimizing operability. The HF120 will use a sophisticated combustor and fuel nozzles designed to reduce NO<sub>x</sub>, CO, HC and smoke emissions. The HF120 is designed to meet noise levels quieter than Stage 4 requirements with substantial margin.

### Maturation

The HF120 builds upon five generations of research and development and will integrate commercially proven designs and materials. It is expected to enter service fully mature from an extensive testing program slated to begin in early 2007, with a target of over 10,000 hours in testing.



**HONDA**

# HF120 Turbofan

## Applications



HondaJet



Spectrum Freedom

## Performance Specifications\*

Takeoff thrust	2,050 lbf.
Bypass ratio	2.9
Engine pressure ratio	24
Thrust/weight ratio	Over 5
Maximum diameter	21.2 in.
Length**	44 in.
Weight	Less than 400 lbs.
Noise	Achieves CFR36 Stage 4 requirements with substantial margin
Specific fuel consumption (cruise, lb. fuel/hr/lbf.)	Less than 0.7
Time between overhaul	5,000 hrs.
Control	Dual-channel FADEC

\*Diagram not to scale. Specifications subject to change without notice.

\*\*Length does not include centerbody.

GE Honda Aero Engines LLC  
 25 Merchant Street, Suite 100  
 Mail Drop U121  
 Cincinnati, OH 45246 USA  
 513.552.3332

gehonda.com

## Dimensions

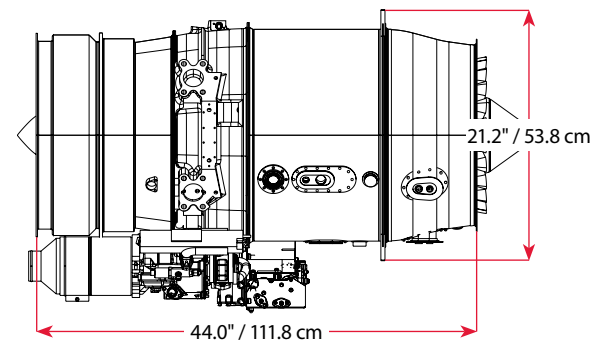

**HONDA**